

ecowitt®



Digital Rain Gauge Receiver

User Manual

Model: WH5370



<https://s.ecowitt.com/9NK90E>

Table of Contents

1. Introduction	1
2. Unpacking	2
2.1 Part list	2
2.2 View and Size	2
3. Set up Guide	4
3.1 Rain Gauge Sensor Pre-Setup	4
3.2 Console power-up and connect with the WN20 rain gauge	5
3.2.1 Power up	5
3.2.2 Connect with the WN20	6
3.3 Console Display	7
3.4 Rain Gauge Sensor(WN20) Mounting	9
3.5 Best Practice for Wireless (RF) Communication	9
3.6 Wireless Signal Strength Indicator	11
3.7 Rainfall Grade Graph	12
3.7.1 Rainfall Range Represented by Colors	12
3.7.2 Rainfall Data Represented	12
4. Button operations and Operating Different Modes ...	13
4.1 Button Operations	13
4.2 Normal Mode	15
4.3 Setting Mode	16
4.4 Calibration Mode	17

4.5 Rain History Mode	18
4.6 MIN/MAX Mode	19
4.7 Alarm/Alert Setting Mode	20
5. Factory Reset and Rain Gauge Sensor Registration ..	22
5.1 Reset to Factory	22
5.2 Rain Gauge Sensor Registration:	22
6. Features	23
7. Troubleshooting Guide	24
8. Specifications	27
9. Warranty Information	28
10. FCC	29
11. Contact Us	32
11.1 After-sales Service	32
11.2 Stay in Touch	33

1. Introduction

Thanks for your purchasing of the WH5370 High Precision Digital Rain Gauge with indoor temperature and humidity sensors. To ensure the best product performance, please read this manual and retain it for future reference.

The WH5370 needs to be used with **Ecovitt WN20 or WH40/WH40H Rainfall sensor** to obtain outdoor rainfall data. This device is not a standalone product.

General Terms Used in the Manual:

Weather Station: Includes the console and sensors (or sensor array).

Receiver: Refers to the console.

Transmitter: Refers to the sensor or sensor array.

RF: Radio frequency. It refers to the ISM and SRD SubG (Industrial, Scientific and Medical and Short Range Devices frequency bands below 1 GHz) for communicating between the console and its sensors. This frequency is not the same as the 4G modem (LTE) or Wi-Fi working frequencies (2.4 GHz, 5 GHz.)

ISM/SRD bands are kept separate from 4G frequencies by national regulations to avoid interferences. Typical ISM/SRD frequencies are 915MHz(Americas), 868MHz(Europe), 433MHz(worldwide), 920MHz (Japan, Korea).

2. Unpacking

2.1 Part list

QTY	Item
1	WH5370 Display Console
1	User manual

Table 1: Package content

2.2 View and Size

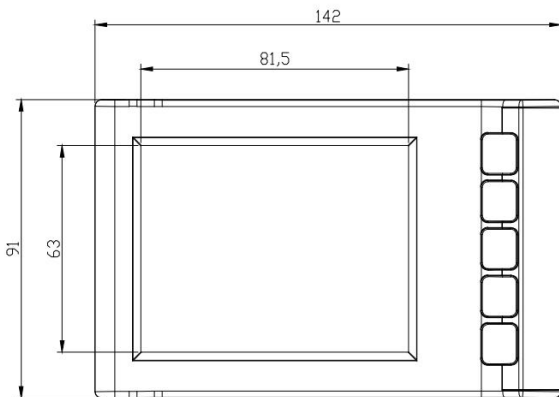

Figure 1 Main view

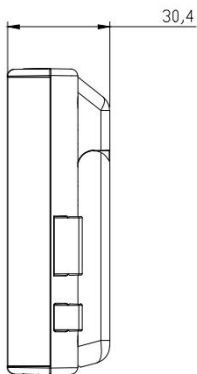

Figure 2 Side view

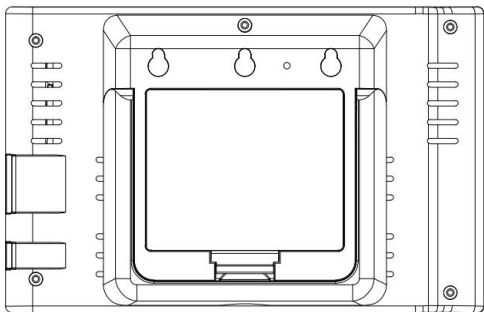

Figure 3 Rear view

3. Set up Guide

Note:

- If **multiple rain sensors (Model: WN20, WH40, or WH40H)** are used, the WH5370 console will display data from the first sensor it receives. To display data from a **specific sensor**, simply **power on that sensor only**.
- We recommend assembling all components of the **WN20 rain gauge first**. Place the WN20 and the WH5370 console together in one location to easily **test functionality**. After testing, install the rain sensor in its desired location.
- However, that movement during and after assembly can cause the rain sensor to **falsely detect rain**. The rain total can be **reset to 0** via the console.

Attention:

- Follow the suggested order for battery installation (outdoor sensor first, then console).
- Ensure batteries are installed with correct polarity (+/-).
- Only use new batteries.

3.1 Rain Gauge Sensor Pre-Setup

Pre-assemble the **WN20** and install the batteries to

power it on, as instructed in the **WN20 Manual section 4.1**. Then, place it next to the WH5370 console.

3.2 Console power-up and connect with the WN20 rain gauge

Note:

- This connection does not require Wi-Fi.
- Make sure that the RF frequency matches (the frequency is different for various countries because of regulations).

3.2.1 Power up

Insert **three AA alkaline batteries** (not included). Once powered on, the unit will show the start-up display for 1 second (Figure 4), followed by a full-screen display for 1 second (Figure 5), and then enter Normal Mode Display(Figure 6).

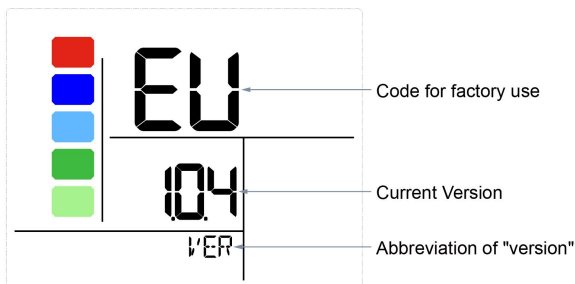

Figure 4 Start-up Screen

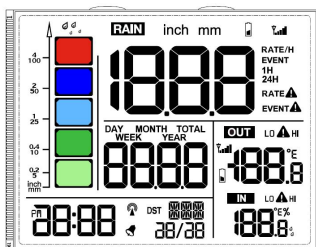

Figure 5 Full-screen Display

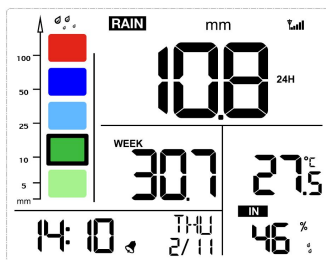

Figure 6 Normal Mode Display

3.2.2 Connect with the WN20

1. After powering up, the next step is to connect it with the **WN20** rain gauge, the console will begin

searching for the **rain gauge sensor (WN20)** data. This may take up to 3 minutes, after which the data will be displayed on the console.

2. If the rainfall data does not appear on the console, hold the RAIN1 / + and RAIN2 / - buttons for 5 seconds. The device will register the transmitter signal for 3 minutes.

3.3 Console Display

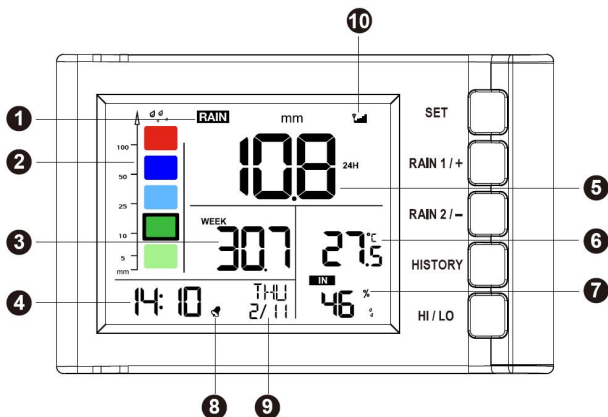

Figure 7 Display Console Screen Layout

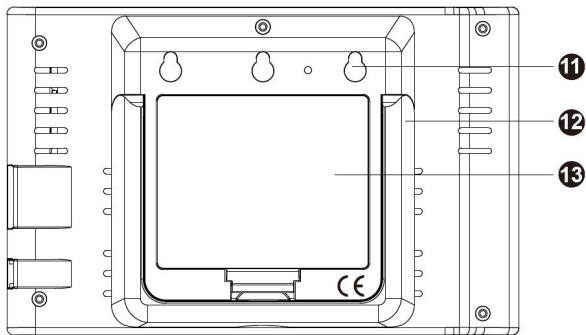

Figure 8 Rear Layout

1.Rainfall data display	8.Alarm icon
2.Rainfall grade graph	9.Date/Week
3.Rainfall of day/week/month/ year display	10.Signal icon
4.Time	11.Wall-mounted hole
5.Rain rate/event/1h/24h display	12.Table stand
6.Indoor temperature	13.Battery door
7.Indoor humidity	

Table 2 Display console detailed items

3.4 Rain Gauge Sensor(WN20) Mounting

Place the rain sensor in the desired location. Refer to **WN20 User Manual Section 5** for details.

3.5 Best Practice for Wireless (RF) Communication

Wireless (RF) communication is susceptible to interference, distance, walls and metal barriers. We recommend the following best practices for trouble free wireless communication between both sensor and the console:

Indoor/outdoor sensor placement: The sensor will have the longest reach for its signal when mounted or hung vertically. Avoid laying it down on a flat surface.

Electro-Magnetic Interference (EMI). Keep the console several feet away from computer monitors and TVs.

Radio Frequency Interference (RFI). If you have other devices operating on the same frequency band as your indoor and/or outdoor sensors and experience intermittent communication between sensor and console, try turning off these other devices for troubleshooting purposes. You may need to relocate the transmitters or receivers to avoid the interference and establish reliable communication. The frequencies used by the sensors are one of (depending on your location): 433, 868, or 915

MHz (915 MHz for United States).

Line of Sight Rating. This device is rated at 300 feet line of sight (under ideal circumstances; no interference, barriers or walls), but in most real-world scenarios, including a wall or two, you will be able to go about 100 feet.

Metal Barriers. Radio frequency will not pass through metal barriers such as aluminum siding or metal wall framing. If you have such metal barriers and experience communication problems, you must change the placement of sensor package and or console.

The following table shows different transmission media and expected signal strength reductions. Each “wall” or obstruction decreases the transmission range by the factor shown below.

Medium	RF Signal Strength Reduction
Glass (untreated)	5-15%
Plastics	10-15%
Wood	10-40%
Brick	10-40%
Concrete	40-80%
Metal	90-100%

Table 3 RF Signal Strength reduction

3.6 Wireless Signal Strength Indicator

During the synchronization, it will reduce one signal segment if it has not received the signal once from the transmitter. It will increase one signal segment if it has received the signal once.

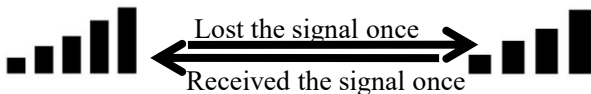

3.7 Rainfall Grade Graph

The rainfall graph displays five colors: cyan, green, blue, dark blue, and red, each representing different rainfall levels. The colors correspond to various rainfall parameters across different modes.

3.7.1 Rainfall Range Represented by Colors































a) mm:	b) Inch:																								
<table><tr><td>mm</td><td></td></tr><tr><td> >100.0 mm</td><td></td></tr><tr><td> 50.1~100.0 mm</td><td></td></tr><tr><td> 25.1~50.0 mm</td><td></td></tr><tr><td> 10.1~25.0 mm</td><td></td></tr><tr><td> 0.1~10.0 mm</td><td></td></tr></table>	mm		 >100.0 mm		 50.1~100.0 mm		 25.1~50.0 mm		 10.1~25.0 mm		 0.1~10.0 mm		<table><tr><td>inch</td><td></td></tr><tr><td> >4.00 inch</td><td></td></tr><tr><td> 2.01-4.00 inch</td><td></td></tr><tr><td> 1.01-2.00 inch</td><td></td></tr><tr><td> 0.41-1.00 inch</td><td></td></tr><tr><td> 0.01-0.40 inch</td><td></td></tr></table>	inch		 >4.00 inch		 2.01-4.00 inch		 1.01-2.00 inch		 0.41-1.00 inch		 0.01-0.40 inch	
mm																									
 >100.0 mm																									
 50.1~100.0 mm																									
 25.1~50.0 mm																									
 10.1~25.0 mm																									
 0.1~10.0 mm																									
inch																									
 >4.00 inch																									
 2.01-4.00 inch																									
 1.01-2.00 inch																									
 0.41-1.00 inch																									
 0.01-0.40 inch																									

Table 4

3.7.2 Rainfall Data Represented

a) Normal Mode:	Shows the historical daily rainfall data.
b) Day Rain History Mode:	Shows the historical daily rainfall data.
c) Month Rain History Mode:	Shows the historical monthly rainfall data.

Table 5

4. Button operations and Operating Different Modes

The device supports multiple operating modes to perform specific functions. Each mode offers unique features and button operations. The following sections explain:

4.1 Button Operations

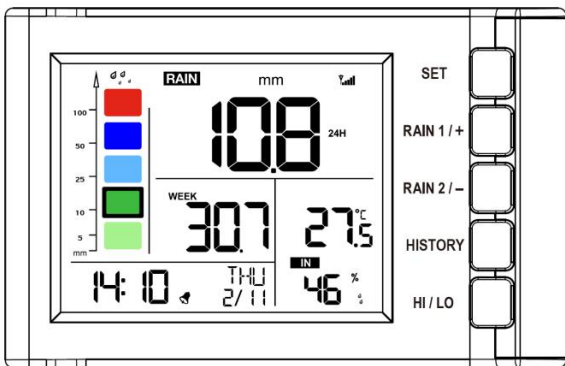

Figure 9 Buttons next to the display

There is a set of five buttons on the right side of the display console. The following table briefly explains the function of these buttons.

Button	Description
SET	Hold for 2 seconds to enter the setting mode.
RAIN 1/+	Press to switch the display between RATE, EVENT, 1H, and 24H (in normal mode).
	Press to increase (+) in Setting Mode.
	Hold for over 5 seconds to clear the currently displayed Rain Rate, Rain Event, or Rainfall Total data.
RAIN 2/-	Press to switch the display between DAY, WEEK, MONTH, YEAR, and TOTAL (in normal mode).
	Press to decrease (-) in Setting Mode.
	Hold for over 5 seconds to clear the currently displayed Day, Week, Month, Year, or Total rainfall data.
RAIN 1/+ & RAIN 2/-	Hold both RAIN 1/+ and RAIN 2/- buttons for 5 seconds to register the transmitter signal for 3 minutes.
HISTORY	Press to toggle between history records of DAY and MONTH, or return to normal mode.
HI/LO	Press to switch the display between MAX and MIN values (in normal mode).
	Hold for 2 seconds to enter the alarm setting and T&H&Rainfall alert setting mode.

Table 6 Console buttons

4.2 Normal Mode

Description:

In Normal Mode, the device displays real-time data. You can switch between different rainfall displays using the RAIN 1/+ and RAIN 2/- buttons.

Using the RAIN 1/+ button:

- **Function: Cycles through:**
 - ◆ Rain Rate (/H)
 - ◆ Rain Event
 - ◆ Rainfall Total for 1 Hour
 - ◆ Rainfall Total for 24 Hours
- **Note:** Holding the RAIN 1/+ button for over 5 seconds clears the currently displayed rainfall data.

Using the RAIN 2/- button:

- **Function: Cycles through:**
 - ◆ Rainfall for the Day
 - ◆ Rainfall for the Week
 - ◆ Rainfall for the Month
 - ◆ Rainfall for the Year
 - ◆ Total Rainfall
- **Note:** Holding the RAIN 2/- button for over 5 seconds clears the currently displayed rainfall data.

4.3 Setting Mode

Entering Setting Mode:

While in Normal Mode, hold the SET button for 2 seconds. The first setting parameter will begin flashing. You can press SET again to skip any step.

Available Settings:

- Beep On/Off
- 12/24 - Hour Format
- Manual Time Setting (Hours/Minutes)
- Date Format (D- M / M- D)
- Date Setting (Year/Month/Day)
- Temperature Unit ($^{\circ}$ C/ $^{\circ}$ F)
- Rainfall Unit (mm/in)
- Calibration Mode

Operation Tips:

- Use the RAIN 1/+ or RAIN 2/- buttons to change or scroll through values.
- Holding these buttons for 2 seconds accelerates the change.
- The device will revert to Normal Mode if idle for 15 seconds or by pressing the HISTORY button.

4.4 Calibration Mode

Entering Calibration Mode:

From within Setting Mode, press SET to toggle till CAL appears.

Function:

- Adjust the calibration coefficient for rainfall measurements.
- Adjustment Range: 0.1 to 5.0 (default is 1.00)

Operation:

- Use the RAIN 1/+ and RAIN 2/- buttons to adjust the coefficient.
- Holding these buttons for 2 seconds changes the value more rapidly.

Before Calibrating, Perform a Rain Gauge Accuracy Cross Check:

Collect Water:

Use a narrow-neck bottle placed under the rain gauge's water outlet to collect water during a rain event.

Measure the weight (e.g., 353 g).

Calculate Rainfall Depth:

Since $353 \text{ g} \approx 353 \text{ ml}$, divide by the rain collector area (250 cm^2):

Calculation: $353 \text{ ml} / 250 \text{ cm}^2 = 1.412 \text{ cm}$, or

approximately 14.1 mm.

Compare Readings:

Compare this calculated rainfall depth with the reading on your console or a calibrated manual gauge.

Adjust for Discrepancies:

Note that due to residual water in the tip bucket and on the collector, the measured rainfall is usually slightly less (within 5%) than the actual amount.

If the deviation exceeds 5%, adjust the calibration settings accordingly or contact customer service for replacement.

Simple Accuracy Check:

1. Remove the rain collector top.
2. Tap the spoon-shaped part inside the bucket 10 times (one tap every 2 seconds).
3. Verify that the console registers approximately 1.0 mm of rainfall after 5 minutes.

4.5 Rain History Mode

Entering Rain History Mode:

While in Normal Mode:

Single Press of the HISTORY button: Enters Day Rain

History Mode.

Double Press of the HISTORY button: Enters Month Rain History Mode.

Operation:

Use the RAIN 1/+ or RAIN 2/- buttons to scroll through historical rainfall data records by day or month.

4.6 MIN/MAX Mode

Entering MIN/MAX Mode:

While in Normal Mode, press the HI/LO button.

Function:

Press the HI/LO button to cycle through maximum and minimum records (with timestamps) for:

- Indoor Temperature (Max/Min)
- Indoor Humidity (Max/Min)

Note:

- Holding the HI/LO button for over 5 seconds clears the currently displayed MAX/MIN records.
- The device will return to Normal Mode if idle for 15 seconds.

4.7 Alarm/Alert Setting Mode

Entering Alarm/Alert Setting Mode:

While in Normal Mode, hold the HI/LO button for 2 seconds. The first alarm setting will begin flashing. Press HI/LO again to skip any step.

Available Settings:

- TIME ALARM: ON/OFF
- TIME ALARM Value (Hour/Minute)
- Rainfall Rate HI Alert: ON/OFF
- Rainfall Rate HI Alert Value
- Rainfall Event HI Alert: ON/OFF
- Rainfall Event HI Alert Value
- Indoor Temperature HI Alert: ON/OFF
- Indoor Temperature HI Alert Value
- Indoor Temperature LO Alert: ON/OFF
- Indoor Temperature LO Alert Value
- Indoor Humidity HI Alert: ON/OFF
- Indoor Humidity HI Alert Value
- Indoor Humidity LO Alert: ON/OFF
- Indoor Humidity LO Alert Value

Operation Tips:

- Use the RAIN 1/+ or RAIN 2/- buttons to change or scroll through values. Holding these buttons for 2 seconds will change values rapidly.
- When an alarm threshold is reached, the corresponding alarm icon flashes and the buzzer rings for 2 minutes. Press any button to stop the buzzer.
- The device will revert to Normal Mode if idle for 15 seconds or by pressing the HISTORY button.

5. Factory Reset and Rain Gauge Sensor Registration

5.1 Reset to Factory

Step 1: Remove the battery from the device.

Step 2: Hold the SET and the HI/LO buttons.

Step 3: While still holding these buttons, reinsert the battery to power up the display.

The device will boot into Factory Mode, and all previously configured settings will be reset to their default values.

5.2 Rain Gauge Sensor Registration:

While in Normal Mode, hold the RAIN 1/+ and RAIN 2/- buttons for 5 seconds.

The device will then register the transmitter signal for 3 minutes.

6. Features

1. Date & Time:

- Calendar display: Month/Day, year range (2017-2099, default year 2019).
- Selectable 12/24-hour format.
- Built-in alarm clock with customizable settings.

2. Indoor Temperature & Humidity:

- Measures indoor temperature and humidity every 60 seconds.
- Records MAX and MIN temperature and humidity with timestamps.
- High and low temperature/humidity alerts.

3. Rain Measurement:

- Receives data from the wireless rain sensor every 49 seconds.
- Rain1 displays: Rain Rate, Rain Event, 1-Hour, 24-Hour rainfall data.
- Rain2 displays: Daily, Weekly, Monthly, Yearly, and Total rainfall data.
- Rain Rate/Event data displayed in graph format.
- Rain Rate alerts and Event alerts.

4. Rainfall History:

- Stores up to 24 months of rain history and 730 days of rainfall records.

7. Troubleshooting Guide

Problem	Solution
<p>Wireless remote (outdoor sensor) not reporting in to console.</p> <p>There are dashes (--) on the display console.</p>	<p>Check the remote-transmitter LED for flashing.</p> <p>The outside sensor has an LED under the plastic, just above the battery compartment. The LED will flash every 49 seconds.</p> <p>If the LED is not flashing every 49 seconds, replace the batteries in the outside sensor.</p> <p>If the batteries were recently replaced, check the polarity.</p> <p>If the sensor is flashing every 49 seconds, proceed to the next step.</p> <p>There may be a temporary loss of communication due to reception loss related to interference or other location factors, or the batteries may have been changed in the remote and</p>

Problem	Solution
	<p>the console has not been reset.</p> <p>The solution may be as simple as powering down and up the console.</p> <ol style="list-style-type: none"> 1. Make sure you have fresh batteries in the display console. 2. With the sensor array and console 10 feet away from each other, remove the batteries from the display console and wait 10 seconds. Put the batteries back in. 3. Do not touch any button for several minutes. 4. If the rainfall data is still showing dashes (--) after 3 minutes, the remote sensor is defective. If the sensor properly syncs up, proceed to the next step “How to prevent intermittent wireless communication”. <p>How to prevent intermittent wireless communication issues:</p> <ol style="list-style-type: none"> 1. Install a fresh set of batteries in the remote sensor array and console.

Problem	Solution
	<p>For cold weather environments, install lithium batteries.</p> <ol style="list-style-type: none"> 2. The maximum line of sight communication range is 300" but most users will get 100" or less due to environmental conditions. Move the sensor and remote closer together. 3. If the sensor assembly is too close (less than 5'), move the sensor assembly away from the display console. 4. Make sure the remote sensors are not transmitting through solid metal like aluminum siding (acts as an RF shield), or earth barrier (down a hill). 5. Move the display console around electrical noise generating devices, such as computers, TVs and other wireless transmitters or receivers. 6. Move the remote sensor to a higher location. Move the remote sensor to a closer location.
Temperature	Make sure the console is placed in a

Problem	Solution
reads too high in the day time.	shaded area on the north facing wall.
Display console contrast is weak	Replace console batteries with a fresh set of batteries.

8. Specifications

Transmission distance(from WN20 or WH40(WH40H) in open field)	100m(328 ft)
Frequency	915/868/433MHz depending on location (North American:915MHz; Europe:868MHz; Other areas:433MHz)
Indoor temperature and humidity data measuring interval	60s
Indoor temperature measuring range	-9.9°C - 60°C (14°F - 140°F)
Indoor temperature accuracy	± 1°F / ±0.56°C
Indoor humidity measuring range	10% - 99%

Indoor relative humidity accuracy (at 25° C):	±6% for 30 - 80% RH
	±5% for 1 - 29% & 80 - 99% RH
Power supply	3xAA Alkaline batteries (not included)
Battery life	12 months

Table 7

9. Warranty Information

We disclaim responsibility for any technical error or printing error or the consequences thereof.

All trademarks and patents are recognized.

We provide a 2 years limited warranty on this product against manufacturing defects or defects in materials and workmanship.

This limited warranty begins on the original date of purchase, is valid only on products purchased, and only to the original purchaser of this product. To receive warranty service, the purchaser must contact us for problem determination and service procedures.

This limited warranty covers only actual defects within

the product itself and does not cover the cost of installation or removal from a fixed installation, normal set-up or adjustments, or claims based on misrepresentation by the seller, or performance variations resulting from installation-related circumstances.

Manufacture: Shenzhen Fine Offset Electronics Co., Ltd.
Address: 4/F, Block C, JiuJiu Industrial City, Shajing Town, Baoan District, Shenzhen City, China

10. FCC

This device complies with part 15 of the FCC Rules. Operation is subject to the condition that this device does not cause harmful interference (1) this device may not cause harmful interference, and (2) this device must accept any interference received, including interference that may cause undesired operation.

Changes or modifications not expressly approved by the party responsible for compliance could void the user's authority to operate the equipment.

NOTE: This equipment has been tested and found to comply with the limits for a Class B digital device, pursuant to Part 15 of the FCC Rules. These limits are designed to provide reasonable protection against

harmful interference in a residential installation. This equipment generates, uses and can radiate radio frequency energy and, if not installed and used in accordance with the instructions, may cause harmful interference to radio communications. However, there is no guarantee that interference will not occur in a particular installation.

If this equipment does cause harmful interference to radio or television reception,

which can be determined by turning the equipment off and on, the user is encouraged to try to correct the interference by one or more of the following measures:

- Reorient or relocate the receiving antenna.
- Increase the separation between the equipment and receiver.
- Connect the equipment into an outlet on a circuit different from that to which the receiver is connected.
- Consult the dealer or an experienced radio/TV technician for help.

To maintain compliance with RF Exposure guidelines, This equipment should be installed and operated with minimum distance between 20cm the radiator your body: Use only the supplied antenna.

IC Caution:

English:

This device contains licence-exempt transmitter(s)/receiver(s) that comply with Innovation, Science and Economic Development Canada's licence-exempt RSS(s). Operation is subject to the following two conditions:

1. This device may not cause interference.
2. This device must accept any interference, including interference that may cause undesired operation of the device.

French:

L'émetteur/récepteur exempt de licence contenu dans le présent appareil est conforme aux CNR d'Innovation, Sciences et Développement économique Canada applicables aux appareils radio exempts de licence. L'exploitation est autorisée aux deux conditions suivantes :

1. L'appareil ne doit pas produire de brouillage;
2. L'appareil doit accepter tout brouillage radioélectrique subi, même si le brouillage est susceptible d'en compromettre le fonctionnement.

11. Contact Us

11.1 After-sales Service

Order Issues:

If you encounter any missing or incorrect shipments of Ecowitt products purchased, please reach out to the respective platform's customer service from the store where you bought the product for assistance.

Usage Inquiries:

Our product is continuously changing and improving, particularly online services and associated applications. To download the latest manual, and additional help, and for any issues related to product usage feel free to contact our customer support team at support@ecowitt.com. We are committed to providing assistance and resolving any concerns you may have.

11.2 Stay in Touch

Ask questions, watch setup videos, and provide feedback on our social media outlets. Follow Ecowitt on Discord, Facebook, YouTube and Twitter.



Copyright © 2025 ecowitt All Rights Reserved. DC101025