

ecowitt[®]



7-in-1 Weather Sensor

Model: WS90



<https://s.ecowitt.com/MP7YJJ>

Table of Contents

1. Introduction	1
2. Instructions for Use	3
2.1 Part List	3
2.2 Size	3
2.3 Over view	4
2.4 Optional accessories(sold separately)	5
3. Configuration and Mount	5
3.1 Preparations	5
3.2 Power up	6
3.3 Pairing with a gateway/console	8
3.3.1 Compatible Gateways/Consoles for WS90	8
3.3.2 Configure with Gateway/Console	10
3.2.3 Replace the old weather sensor	10
3.4 View Online Data on Ecowitt APP	11
3.5 Before you mount	11
3.6 Final mount	12
3.6.1 Note for Southern Hemisphere Installation:	12
3.6.2 Before mount	12
3.6.3 Extension cable(sold separately) introduction	12
3.6.4 Pole Attachment	13
3.6.5 Correctly Align the WS90 Sensor	15
3.6.6 Final Steps	16
4. Features	17
5. Specifications	17

6. Calibration and Maintenance	20
6.1 About daily rain deviation	20
6.2 How to calibrate WS90	21
6.2.1 A certain parameter Calibration	21
6.2.2 Rain Sensor Calibration	23
6.3 Wind Speed 0 Calibration.	25
6.4 Managing LED Flashing	26
7. Warranty	26
8. FCC	28
9. Care and Maintenance	30
10. Contact Us	32
10.1 After-sales Service	32
10.2 Stay in Touch	33

1. Introduction

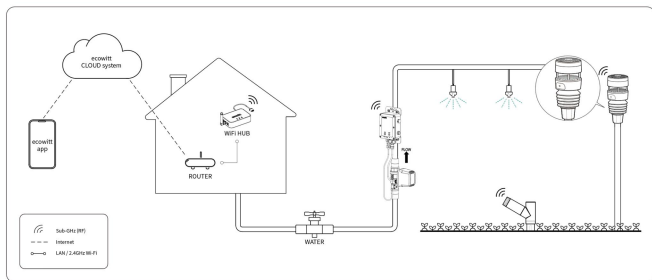

Figure 1 Ecowitt Ecosystem

Thank you for purchasing the WS90 7-in-1 Outdoor Sensor. This device is designed to measure multiple weather parameters, including temperature, humidity, wind speed, wind direction, rainfall, UV, and light intensity.

Please note that this sensor cannot be used alone. The data can be transmitted via the Ecowitt Wi-Fi Gateway or displayed on a receiver console (sold separately). Once the Wi-Fi configuration is complete, the data can be viewed on the Ecowitt app or on the receiver console.

To ensure optimal product performance, please read this

manual carefully and keep it for future reference.

General Terms Used in the Manual:

Gateway:

Also known as a hub, it is a display-less console

Receiver:

Refers to the console.

RF: Radio frequency.

It refers to the ISM and SRD SubG (Industrial, Scientific and Medical and Short-Range Devices frequency bands below 1 GHz) for communicating between the console and its sensors.

This frequency is not the same as the 4G modem (LTE) or Wi-Fi working

frequencies (2.4 GHz, 5 GHz.) ISM/SRD bands are kept separate from 4G frequencies by national regulations to avoid interference. Typical ISM/SRD frequencies are 915MHz(Americas), 868MHz(Europe), 433MHz(worldwide), 920MHz (Japan, Korea)

2. Instructions for Use

2.1 Part List

1 x WS90 Weather Sensor

1 x User Manual

2.2 Size

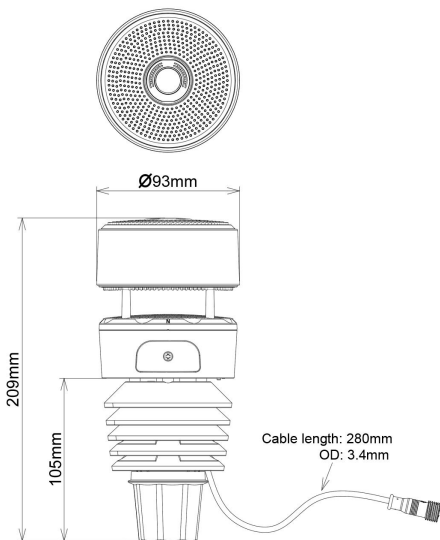

Figure 2

2.3 Over view



Figure 3 Sensor package assembly components

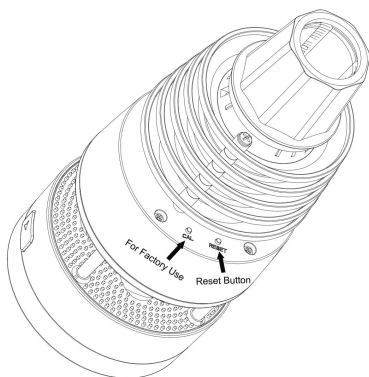

Figure 4 Cal button & Reset button

2.4 Optional accessories(sold separately)

Optional accessories(sold separately)	
12V/1A power extension cord	There's a built-in heat plate in the 7-in-1 sensor package body, if the lowest temperature at your place is below 0°C, or 32°F, and the weather is mostly snowy or rainy, then you may need to activate the heater by supplying an external 12V/1A power to the sensor heating element for melting accumulated snow or ice.
Bird spikes	The Detachable Metal Bird Spikes Set for Rain Gauge is designed to discourage birds from landing on the sensor.

Table 1

3. Configuration and Mount

3.1 Preparations

1. Open the package.
2. Preparing the receiver (gateway or console) to pair with the WS90.

3.2 Power up

Battery Usage Warning	
Correct Battery Installation	Ensure the battery is inserted with the correct polarity. The system requires initial power from this backup battery to start up before the solar panel charges the accumulator and supplies system power.
Cold Weather Considerations	In high-altitude areas during winter, sunlight exposure is limited, and the system relies more on the backup battery. We recommend using lithium batteries for better performance in cold climates.
Avoid Alkaline Batteries for Heated Operation	If the internal heater is activated during cold and wet conditions, heat will build up inside the device. Alkaline batteries are highly prone to leakage when exposed to high temperatures and should be avoided in such scenarios.
Battery Type Recommendations	Alkaline batteries can be used but should be avoided if the heater is activated. Rechargeable NiMH or NiCd batteries should not be used as they are not suitable for this system.

Table 2

Use a screwdriver to open the battery compartment and insert 2 AA batteries. The LED on the back of the sensor will light up for 3 seconds and then blink every 8.8 seconds, indicating that the sensor is transmitting data properly.

If the LED does not light up for 3 seconds or does not blink as expected, press the "Reset" button to restart the process and ensure that the LED blinks every 8.8 seconds.

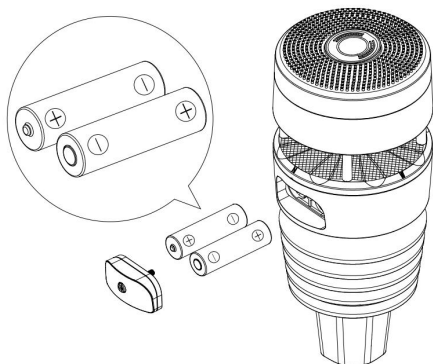





Figure 5 Battery installation diagram

3.3 Pairing with a gateway/console

3.3.1 Compatible Gateways/Consoles for WS90

You need to pair this device with the Ecowitt Wi-Fi Gateway or display consoles in order to view data on your Ecowitt app and receive email alerts on our weather server. Compatible models are listed in the table below.

Console Model Name	Picture	Whether the data could Upload to Internet	Whether the data Could Display on the Gateway/ Console
GW1100		√	×
GW1200		√	×
GW2000		√	×
GW3000		√	×

HP2550		√	√
HP2560		√	√
HP3500		√	√
WN1820/ WN1821		√	×
WN1900/ WN1910		√	×
WN1920/ WN1980		√	×
WS3800		√	√
WS3900/W S3910		√	√
WS6210		√	×

Table 3

- The WN1900/WN1910/WN1920/WN1980 can't display the light intensity and UV data(Uploading not affected).
- The WN1820/WN1821 only displays the outdoor

temperature and humidity data(Uploading not affected).

3.3.2 Configure with Gateway/Console

For details in this part, please refer to the manual of the gateway/console.

If Wi-Fi gateway has been in operation, and you have never had a weather sensor setup before, the sensor and Wi-Fi gateway will pick its data automatically.

3.2.3 Replace the old weather sensor

If you want to use a new WS90 sensor to replace a old weather sensor (already configured on certain channel), please try the following:

- 1.Open the Sensor ID page on the Ecowitt app, and find your old sensor ID.
- 2.Power off the old sensor and power on the new sensor.
- 3.Click Re-register on the Sensor ID page.

Then the new sensor will be learned, and the old sensor will be erased.

3.4 View Online Data on Ecowitt APP

When the Wi-Fi configuration is done, you can view the live data of your weather sensor on the Ecowitt app.

3.5 Before you mount

Before mounting the outdoor sensor in a permanent location, you should test the sensor wireless connection in a temporary location, and make sure that the sensor has a good station to show the data on the app or console. At the same time, you can adroitly use the various functions and familiarize yourself with the performance of the device.

3.6 Final mount

3.6.1 Note for Southern Hemisphere Installation:

The solar panel is rounded and orientation-free, so there is no need to adjust it to face "SOUTH" for charging capability.

3.6.2 Before mount

Familiarize yourself with the WS90's bottom threaded cover by gently turning it left and right to understand how it screws on and off.

3.6.3 Extension cable(sold separately) introduction

- The WS90 has the extension cable to connect the waterproof adapt 12V.
- The extension cord can also power the entire sensor, not just melts the ice.
- If you are not using the external heater, you can store the heater cable inside the pole fixing thread. This helps keep the setup neat and tidy while preventing accidental damage.

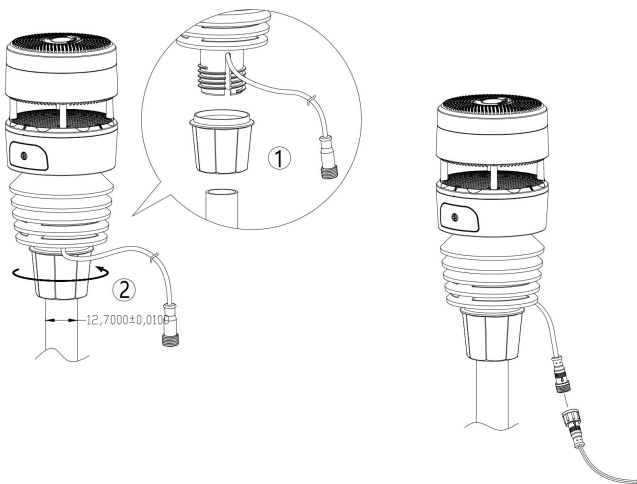

Figure 6

3.6.4 Pole Attachment

- You can attach a pole (not included) to a permanent structure and then mount the sensor onto it (refer to Figure 7 for guidance).
- The installation hole is designed to fit a pole with a diameter of 1.0 inch (pole not included).

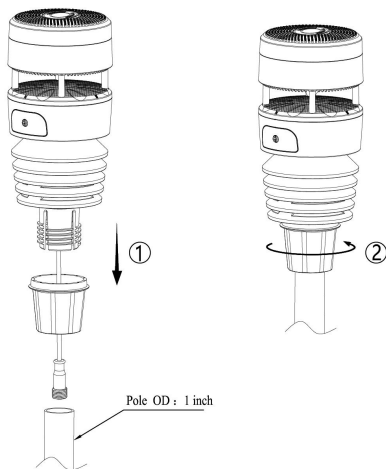

Figure 7 Sensor package mounting diagram

- **Vertical Alignment**

Ensure the mounting tube for the sensor package is installed upright to maintain proper vertical alignment. Adjust the mounting pipe as needed to achieve this.

- **Leveling the Anemometer**

Make sure the anemometer body is mounted level on the pipe. If it is not level, wind direction and speed readings may be inaccurate. Adjust the mounting assembly if necessary.

3.6.5 Correctly Align the WS90 Sensor

- If you are unsure about the correct direction, locate the arrow labeled "**NORTH**" on top of the sensor package's connector tube.
- Rotate the sensor until this arrow points due **NORTH**. You can verify the direction using a compass app on your phone.
- Once aligned, securely screw the bottom threaded cover in the **NORTH** direction, as shown in Figure 8:

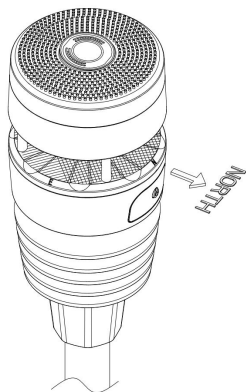

Figure 8

3.6.6 Final Steps

- Before tightening the bolts, double-check and correct the north orientation as the final installation step.
- Tighten the bolts securely, but avoid over-tightening. Ensure the sensor is firmly fixed to withstand strong winds and rain without moving.

4. Features

- Piezoelectric rain gauge;
- Ultrasonic anemometer (start wind speed 0.5m/s);
- Outdoor Temperature and Humidity;
- Solar light intensity and UV index;
- Waterproof IPX5;
- Heater and additional power supply;

5. Specifications

Model	WS90
Name	Ultrasonic Anemometer with Piezoelectric Rain Gauge, Light & UV, Thermo-hygrometer Sensors
Dimensions	93*93*208mm
Weight	498(g)
Material of Plastic Casing	ASA+PC、PC
Temperature Metering Range	-40°C to 60°C(-40°F to 140°F)
Temperature Metering Accuracy	±1°C (± 1.8°F)
Temperature Metering Resolution	0.1°C (0.2°F)

Humidity Metering Range	1%RH to 99%RH
Humidity Metering Accuracy	±5%RH
Humidity Metering Resolution	1%RH
Rainfall Metering range	0mm to 9999mm
Rainfall Metering accuracy	±20%, <5mm/h & >50mm/h; ±10%, 5mm/h to 50mm/h;
Rainfall Metering resolution	0.1mm
Wind speed Metering range	0m/s to 40m/s
Wind speed Metering accuracy	±1m/s, <10m/s; ±10%, ≥10m/s
Wind speed measurement interval	2s
GUST wind speed interval	28 seconds
Wind speed Metering resolution	0.1m/s (starting speed > 0.5m/s)
Wind direction Metering range	0° to 359°
Wind direction Metering accuracy	±15°
Wind direction	1°

Metering resolution	
Light Metering range	0Klux to 200Klux
Light Metering accuracy	±25%
Light Metering resolution	0.1Klux
UV Metering range	1 to 15
UV Metering accuracy	±2
UV Metering resolution	1
Data reporting Interval	8.8 seconds
RF Connection Frequency	920/915/868/433MHz (depending on local regulations)
RF Wireless Range (in open areas)	Over 150 meters (500 ft.)
Operating Temperature Range	-40°C to 60°C(-40°F to 140°F)
Protection Rating	IPX5
Built-in Solar panel	7.5V±5%/30mA±10%
Power Supply	2*AA batteries(not included) or DC12V/1A Power adapter (not included)
Battery Life	3 to 4 months(when no rainfall); 1 to 2 months(when continuous rainfall).

Table 4

Note:

- The wind speed is detected by every 2s.
- The wind speed reading will be a real-time value (The latest sampling data will be reporting to the receiver).
- The wind gust reading will be the max wind speed in the past 28s.
- When the wind speed is lower than 5m/s, the dispersion of wind direction will increase.
- The primary power source for the sensor is the solar panel. When available solar power (light over recent period) is insufficient, the batteries will be used.

6. Calibration and Maintenance

6.1 About daily rain deviation



Figure 9 Daily rain deviation for WH40 and WS90

The daily rain deviation of WS90 is very small in the long run, but under certain conditions the deviation can be larger: as the rain drop size and wind speed can have different impacts on the sensor output which lead to this variance.

The WS90 product suffer from this imperfectness. If you are very demanding on rain data accuracy, we suggest you buy WH40 and use it together with WS90. If there is no precise requirement on data of each rain, then WS90 is just fine: After all the device works well after a longer run time.

6.2 How to calibrate WS90

Ensure WS90 has been paired with the gateway/console. Make sure your mobile device and the gateway/console are connected to the same Wi-Fi network.

6.2.1 A certain parameter Calibration

If you have data from a relatively accurate weather station. You can use the data to do the calibration. Use Indoor temperature as an illustration in the Figure 10.

1. Open the Ecowitt app. Click "... " on top right corner

and choose "Calibration".

2. Calculate the offset of data from accurate weather station and ecowitt sensor.

3. Fill in the offset got from step3, click Save.

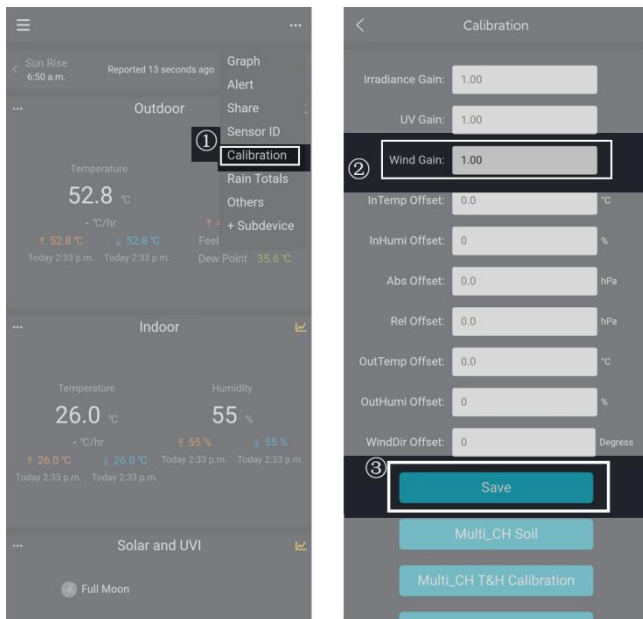

Figure 10

6.2.2 Rain Sensor Calibration

The WS90 is equipped with a haptic rain sensor, and the system provides a method for users to calibrate the accuracy of the rain sensor themselves. To perform a proper calibration, please follow these steps:

1. Prepare a Reference Device

A reference device is needed to record rainfall values, and it is also crucial to have the ability to record rain rates. For this purpose, the WH40 rain sensor can be used as the reference device.

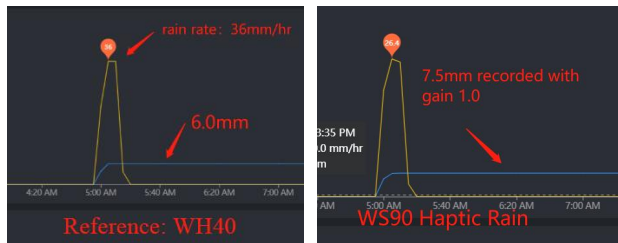

Figure 11 Rainfall values recorded for WH40 and WS90

2. Understand Rain Gain Parameters

There are five rain gain parameters that can be set: Piezo Rain1 to Rain5. It is recommended to leave Rain1 unchanged unless you can confirm that it consistently produces the same results, after which you can adjust it.

3. Record and Calculate Rainfall Data

For example: Suppose we set the Rain4 gain to $6/7.5 = 0.8$. For easier handling, you can temporarily set Rain2, Rain3, and Rain5 to 0.8 as well.

Only when different rain rates are recorded should you divide the WS90 rainfall value by 0.8 to obtain a 1.0 rainfall value. Then, recalculate (reference value/WS90/0.8) and precisely fill in the corresponding rain gain settings.

Piezo Rain1 Gain	1.00	When rain rate less than 4 mm/h, Range: 0.10 - 5.00
Piezo Rain2 Gain	1.00	When rain rate less than 10 mm/h, Range: 0.10 - 5.00
Piezo Rain3 Gain	1.00	When rain rate less than 30 mm/h, Range: 0.10 - 5.00
Piezo Rain4 Gain	1.00	When rain rate less than 60 mm/h, Range: 0.10 - 5.00
Piezo Rain5 Gain	1.00	When rain rate more than 60 mm/h, Range: 0.10 - 5.00

Figure 12 Set five rain gain parameters

By following these steps, you can more accurately calibrate the rain sensor of the WS90.

6.3 Wind Speed 0 Calibration.

Wind speed needs to be re-zeroed after the firmware upgrade (establish the zero baseline)

Use a fan to test if the wind speed responds at all angles !

1. Perform calibration in a windless room. Cover the top and wind speed sensor area of the WS90 with a soft cloth.

- Hold the CAL button for 3 seconds until the LED lights up for 5 seconds and starts flashing.
- Wait until the LED turns off, indicating that the wind speed calibration is complete and reset to the zero baseline is done.

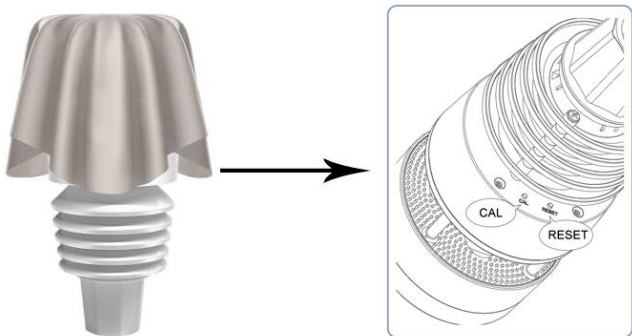

Figure 13

6.4 Managing LED Flashing

For some, the LED flashing is disturbing.

- To stop the LED from flashing, press and release the CAL button three times shortly.
- To restart the LED light function, press the CAL button three times again.

7. Warranty

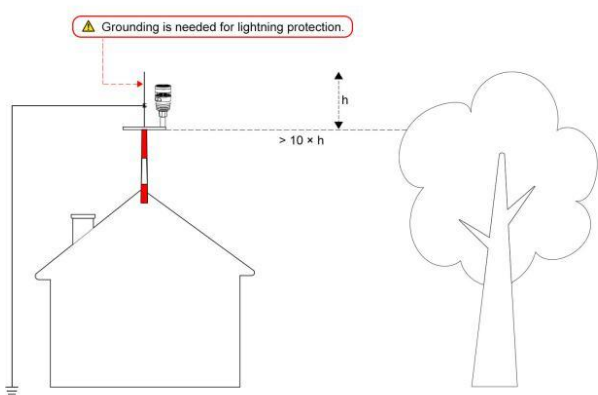

Figure 14

Note: Sensor damage, due to lack of grounding protection against lightning ESD discharge, is not covered by warranty.

We disclaim any responsibility for any technical error or printing error or the consequences thereof.

All trademarks and patents are recognized.

We provide a 2-year limited warranty on this product against manufacturing defects or defects in materials and workmanship.

This limited warranty begins on the original date of purchase, is valid only on products purchased, and only to the original purchaser of this product. To receive warranty service, the purchaser must contact us for problem determination and service procedures.

This limited warranty covers only actual defects within the product itself and does not cover the cost of installation or removal from a fixed installation, normal set-up or adjustments, or claims based on misrepresentation by the seller, or performance variations resulting from installation-related circumstances.

8. FCC

This device complies with part 15 of the FCC Rules. Operation is subject to the following conditions: (1) this device should not cause harmful interference, and (2) this device must accept any interference received, including interference that may cause undesired operation.

Changes or modifications not expressly approved by the party responsible for compliance could void the user's authority to operate the equipment.

NOTE: This equipment has been tested and found to comply with the limits for a Class B digital device, pursuant to Part 15 of the FCC Rules. These limits are designed to provide reasonable protection against harmful interference in a residential installation. This equipment generates, uses and can radiate radio frequency energy and, if not installed and used in accordance with the instructions, may cause harmful interference to radio communications. However, there is no guarantee that interference will not occur in a particular installation.

If this equipment does cause harmful interference to radio or television reception, which can be determined by turning the equipment off and on, the user is encouraged

to try to correct the interference by one or more of the following measures:

- Reorient or relocate the receiving antenna.
- Increase the separation between the equipment and receiver.
- Connect the equipment to an outlet on a circuit different from that to which the receiver is connected.
- Consult the dealer or an experienced radio/TV technician for help.

To maintain compliance with RF Exposure guidelines, This equipment should be installed and operated with a minimum distance between 20cm of the radiator and your body. Use only the supplied antenna.

IC Caution:

English:

This device contains license-exempt transmitter(s)/receiver(s) that comply with Innovation, Science, and Economic Development Canada's license-exempt RSS(s). Operation is subject to the following two

Conditions:

1. This device may not cause interference.
2. This device must accept any interference, including interference that may cause undesired operation of the device.

French:

L'émetteur/récepteur exempt de licence contenu dans le présent appareil est conforme aux CNR d'Innovation, Sciences et Développement économique Canada applicables aux appareils radio exempts de licence.

L'exploitation est autorisée aux deux conditions suivantes :

1. L'appareil ne doit pas produire de brouillage;
2. L'appareil doit accepter tout brouillage radioélectrique subi, même si le brouillage est susceptible d'en compromettre le fonctionnement.

Manufacture: Shenzhen Fine Offset Electronics Co., Ltd.

Address: 4/F, Block C, JiuJiu Industrial City, Shajing Town, Baoan District, Shenzhen City, China

9. Care and Maintenance

When batteries of different brands or types are used together, or new and old batteries are used together, some batteries may be over-discharged due to a difference in voltage or capacity. This can result in venting, leakage, and rupture and may cause personal injury.

- Do not mix Alkaline, Lithium, standard, or rechargeable batteries.

- Always purchase the correct size and grade of battery most suitable for the intended use.
- Always replace the whole set of batteries at one time , taking care not to mix old and new ones, or batteries of different types.
- Clean the battery contacts and also those of the device prior to battery installation.
- Ensure the batteries are installed correctly with regard to polarity (+ and -).
- Remove batteries from products during periods of non-use. Battery leakage can cause corrosion and damage to this product.
- Remove used batteries promptly.
- For recycling and disposal of batteries, and to protect the environment, please check the internet or your local phone directory for local recycling centers and/or follow local government regulations.

The provided solar panel charges a super capacitor on this WS90. In normal conditions (solar light intensity over 20klux and lasted longer than 4 hours), the super capacitor peak voltage displayed on the battery tile from your dashboard should be above 3.5v and lower than

5.5v. If it is not overpassing 2.5v, please check the top part of your WS90, and make sure it is free from dust coverage. Use a brush to clean up the surface for higher solar charging efficiency.

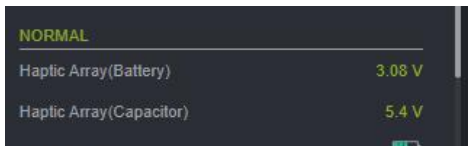

Figure 15

10. Contact Us

10.1 After-sales Service

Order Issues:

If you encounter any missing or incorrect shipments of Ecowitt products purchased, please reach out to the respective platform's customer service from the store where you bought the product for assistance.

Usage Inquiries:

Our product is continuously changing and improving, particularly online services and associated applications. To download the latest manual, and additional help, and

for any issues related to product usage feel free to contact our customer support team at support@ecowitt.com. We are committed to providing assistance and resolving any concerns you may have.

10.2 Stay in Touch

Ask questions, watch setup videos, and provide feedback on our social media outlets. Follow Ecowitt on Discord, YouTube, Facebook and Twitter.



Patented: US12,181,491B2

This product (WS85, WS80, WS90) is protected by US Patent No. 12,181,491B2.

Copyright©2025 ecowitt All Rights Reserved. DC031225